

# **3M Macurco™ CM-21A Carbon Monoxide Detector and Controller**

User Instructions for 3M Macurco CM-21A - Low voltage, dual relay Carbon Monoxide (CO) detector and controller



Important: Keep these User Instructions for reference

# TABLE OF CONTENTS

GENERAL SAFETY INFORMATION	3
Intended Use	3
List of Warnings and Cautions	3
USE INSTRUCTIONS AND LIMITATIONS	3
Use For	3
Do Not Use For	4
General Description	4
Features	4
Specifications	4
INSTALLATION AND OPERATING INSTRUCTIONS	4
General Information	4
Location	4
Installation	5
Power Up	6
Selecting Fan Relay Level	6
Selecting Alarm Relay Operation	6
On Board Diagnostics	7
Brown-Outs	7
Sensor Poisons	7
MAINTENANCE	7
Cleaning	7
Calibration Verification Test	7
Carbon Monoxide Gas Test	8
3M™ GAS DETECTION PRODUCTS WARRANTY	8
FOR MORE INFORMATION	8

## GENERAL SAFETY INFORMATION

### Intended Use

The 3M™ Macurco™ CM-21A is a low voltage, dual relay Carbon Monoxide (CO) detector and controller. The CM-21A uses an electronic detection system to measure the concentration of CO and provide automatic exhaust fan control to help ensure a safe environment in parking garages or maintenance facilities. The CM-21A is factory calibrated and 100 % tested for proper operation, but can also be calibrated in the field.

### List of Warnings and Cautions within these User Instructions

#### **WARNING**

- Each person using this equipment must read and understand the information in these *User Instructions* before use. Use of this equipment by untrained or unqualified persons, or use that is not in accordance with these *User Instructions*, may adversely affect product performance and **result in sickness or death**.
- Use only for monitoring the gas which the sensor and instrument are designed to monitor. Failure to do so may result in exposures to gases not detectable and **cause sickness or death**. For proper use, see supervisor or *User Instructions*, or call 3M in U.S.A., 1-800-243-4630. In Canada, call Technical Service at 1-800-267-4414.
- CM-21A may not function effectively below 0 °F or above 125°F. Using the detector outside of this temperature range may adversely affect product performance and **result in sickness or death**.
- This detector helps monitor for the presence and concentration level of certain specified airborne gases. Misuse may produce an inaccurate reading, which means that higher levels of the gas being monitored may be present and could result in overexposure and **cause sickness or death**. For proper use, see supervisor or *User Instructions*, or call 3M in U.S.A., 1-800-243-4630. In Canada, call Technical Service at 1-800-267-4414.
- Each time the unit is turned on it performs a self-test, which activates visual alarms. If the self-test fails, or all the alarms do not activate, do not use. Failure to do so may adversely affect product performance and **result in sickness or death**.
- Do not cover or obstruct visual alarm LED. Doing so may adversely affect product performance and **result in sickness or death**.
- Do not disassemble unit or attempt to repair or modify any component of this instrument. This instrument contains no user serviceable parts, and substitution of components may impair product performance and **result in sickness or death**.
- Using a certified gas with a concentration other than the one listed for this instrument and sensor when conducting a calibration or calibration verification test (bump test) will produce inaccurate readings. This means that higher levels of the gas being monitored may be present and could result in overexposure and **cause sickness or death**. For proper use, see supervisor or *User Instructions*, or call 3M in U.S.A., 1-800-243-4630. In Canada, call Technical Service at 1-800-267-4414.
- The following steps must be performed when conducting a calibration or calibration verification test (bump test) to ensure proper performance of the monitor. Failure to do so may adversely affect product performance and **result in sickness or death**.
  - When performing a calibration or calibration verification test (bump test) only use certified calibration gas at the required concentration level. Do not calibrate with expired calibration gas.
  - If the instrument cannot be calibrated, do not use until the reason can be determined and corrected.
  - Do not cover or obstruct display or visual alarm cover.
  - Ensure sensor inlet is unobstructed and is free of debris

## USE INSTRUCTIONS AND LIMITATIONS

#### **WARNING**

Each person using this equipment must read and understand the information in these *User Instructions* before use. Use of this equipment by untrained or unqualified persons, or use that is not in accordance with these *User Instructions*, may adversely affect product performance and **result in sickness or death**.

---

### Use For

The CM-21A provides CO detection and automatic exhaust fan control for automotive maintenance facilities, enclosed parking garages, warehouses with forklifts, etc. The CM-21A meets the requirements of the Uniform Building Code for enclosed garages and meets OSHA standards for CO exposure. CM-21A can be used with 12VDC or 24VDC N.O. (fire/security) panels.

#### **WARNING**

Use only for monitoring the gas which the sensor and instrument are designed to monitor. Failure to do so may result in exposures to gases not detectable and **cause sickness or death**. For proper use, see supervisor or *User Instructions*, or call 3M in U.S.A., 1-800-243-4630. In Canada, call Technical Service at 1-800-267-4414.

---

## Do Not Use For

The CM-21A is **NOT** intended for use in industrial applications such as refineries, chemical plants, etc. **Do NOT** mount the CM-21A where the normal ambient temperature is below 0° F or exceeds 125° F. The CM-21A mounts on a type 4S electrical box supplied by the contractor. **DO NOT** install the CM-21A inside another box unless it has good air flow through it.



## WARNING

CM-21A may not function effectively below 0 °F or above 125°F. Using the detector outside of this temperature range may adversely affect product performance and **result in sickness or death**.

---

## General Description

The CM-21A is a low voltage, dual relay Carbon Monoxide (CO) detector and Automatic ventilation controller. The CM-21A uses a Microcomputer controlled, electronic system to measure the concentration of CO and calculates when the relays should be actuated. The CM-21A is low maintenance with no periodic calibration needed and a long life (7 to 10 years) solid-state sensor.

## Features

- CM-21A provides CO detection and automatic exhaust fan control for automotive maintenance facilities, enclosed parking garages, warehouses with forklifts, etc.
- Selectable fan and alarm relay activation
- 5 amp SPDT fan relay controls starters of exhaust fans
- 1/2 amp N.O. or N.C. alarm relay connects to warning devices or control panels
- CM-21A mounts on a standard 4x4 electrical box and becomes cover for the box
- Supervised system: any internal detector problem will cause the fan relay to activate
- Optional calibration kit is available. One screw allows access for calibration

## Specifications

- Power: 3 watts from 12 to 24 VAC or VDC
- Current: 12 V - 0.25 amps, 24 V - 0.12 amps
- Shipping Weight: 1 pound
- Size: 4 1/2 x 4 x 2 1/8 in.
- Color: gray
- Connections: 7 each #20 wires, 6 inches long
- Mounting box: (not included) 4x4 electric
- Fan relay: 5 amp, 240 VAC, pilot duty, SPDT
- Fan relay actuation: selectable at 25ppm, 35ppm (default), 50ppm or 100ppm CO within 5 min.
- Alarm relay: 0.5 amp 200 V, 10 VA
- Alarm relay actuation: selectable at 100ppm CO within 3 hours or 200ppm CO within 10 min.
- Operating Environ: 0 to 125 F, 10 to 90 % RH

## INSTALLATION AND OPERATING INSTRUCTIONS

The following instructions are intended to serve as a guideline for the use of the 3M Macurco™ CM-21A Carbon Monoxide Detector. It is not to be considered all-inclusive, nor is it intended to replace the policy and procedures for each facility.



## WARNING

This detector monitors for the presence and concentration level of certain specified airborne gases. Misuse may produce an inaccurate reading, which means that higher levels of the gas being monitored may be present and could result in overexposure and **cause sickness or death**. For proper use, see supervisor or *User Instructions*, or call 3M in U.S.A., 1-800-243-4630. In Canada, call Technical Service at 1-800-267-4414.

---

If you have any doubts about the applicability of the equipment to your job situation, consult an industrial hygienist or call 3M at 1-800-243-4630. In Canada, call Technical Service at 1-800-267-4414.

## General Information

The CM-21A is a low voltage, dual relay Carbon Monoxide (CO) detector and controller. It uses an electronic detection system to measure the concentration of CO and provide automatic exhaust fan control to help ensure a safe environment in parking garages or maintenance facilities. The unit has the ability to be calibrated in the field.

## Location

The unit typically covers about 5000 sq. ft. The coverage depends on air movement in the room or facility. Do NOT mount the CM-21A in a corner. Normally, the unit mounts 5 feet above the floor, in a central area where air movement is generally good. Additional detectors may be needed near any areas where people work or the air is stagnant.

## Installation

1. The CM-21A mounts on a type 4S electrical box supplied by the contractor. Do *not* mount the CM-21A inside another box, *unless* it has good air flow through it.
2. It is suggested to use a separate transformer for powering the unit or units because of possible interference's from other devices on the same power supply that may cause the CM-21A microcontroller to become erratic.
3. Connect the CM-21A wires to the control cable with wire nuts. When making connections, make sure the power is off.

### TYPICAL INSTALLATION IN SMALL GARAGE

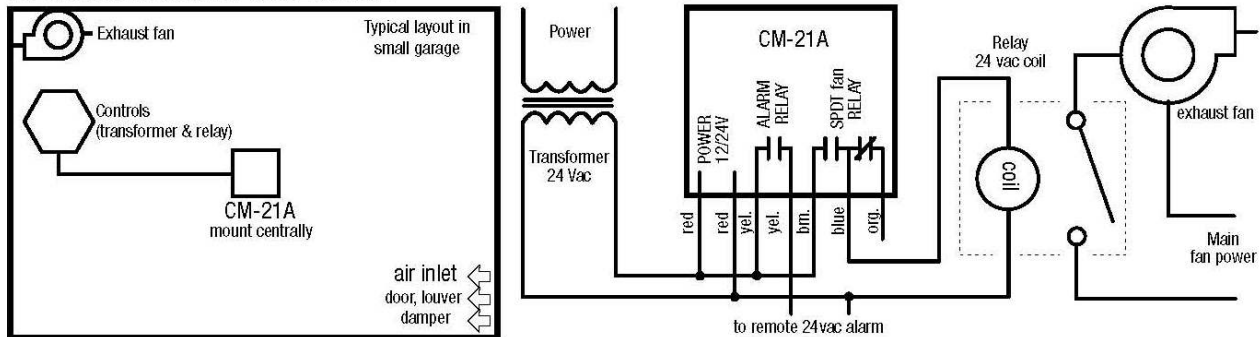

4. The two **Red** wires are the power: 12 to 24VAC or VDC (26.5 max.), with no polarity preference.
5. The two **Yellow** wires are the dry, Normally Open (N.O.) Alarm relay contacts, again with no polarity preference. The Alarm relay is activated if CO vs. time is exceeded. The Alarm relay can switch up to 0.5 Amp, 200 V, or 10 VA. This relay can also be set to be Normally Closed (N.C.).
6. The dry contact, SPDT Fan relay has three wires. The **Blue** wire is common (COM.). The **Brown** wire is the Normally Open (N.O.) contact. The **Orange** wire is the Normally Closed (N.C.) contact. The Fan relay can switch up to 5.0 Amps up to 240 VAC. The Fan relay switches if there is 35 ppm or more of CO for two or more sampling cycles (5 minutes average). Other fan relay activation settings are selectable (see OPERATION section for details on relay settings).

### TYPICAL MULTIPLE CM-21A INSTALLATION

#### INSTALLATION NOTES

1. One sensor per 5000 square feet (approximately).
2. Mount CM-21A four to five feet above the floor.
3. See applicable building code for fan size vs air changes per periods of time.
4. Make sure there are air inlets to provide adequate air flow throughout the building.
5. CM-21A fan relays are dry contact & can switch up to 240V; see ratings, over.
6. Several fan relays (starters) may be used. Match the relays to the fan size.

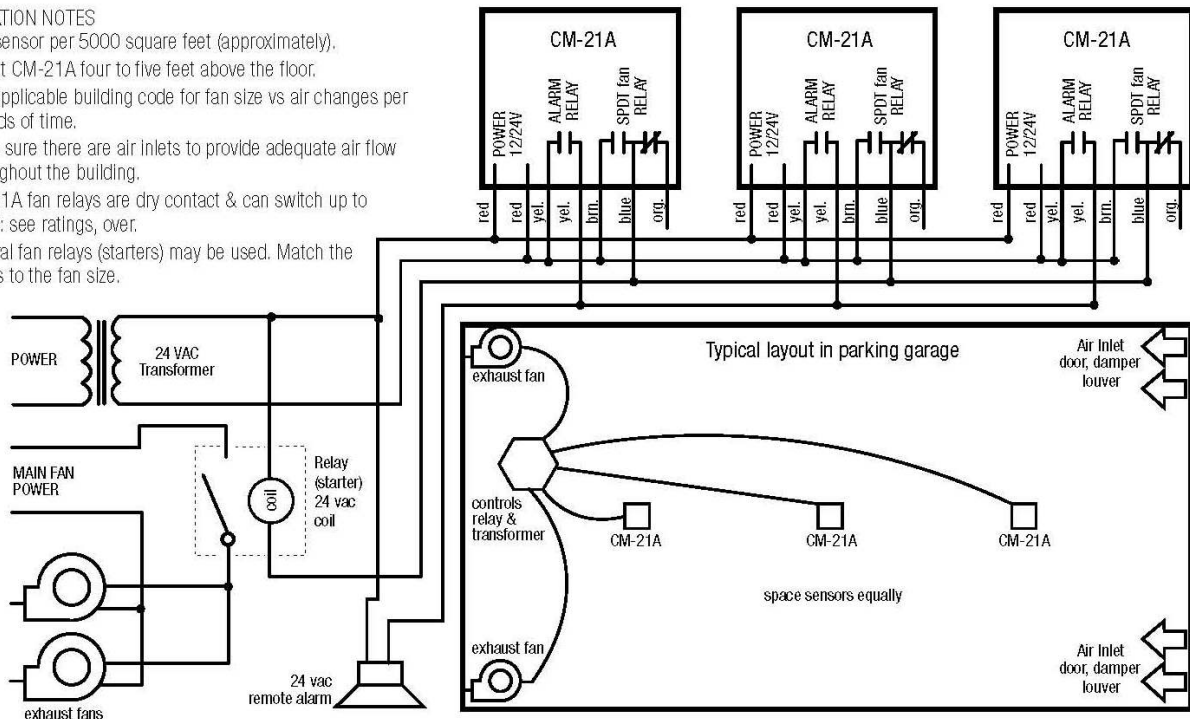

### TYPICAL CONNECTION TO ALARM CONTROL PANEL

1. CM-21A can be used with 12vdc or 24vdc N.O. (fire) panels.
2. Alarm panel provides battery backed up power to CM-21A.
3. CM-21A dry contact fan relay can use panel power or fan power: check ratings.
4. Match fan relay contacts to fan size, and coil voltage to power source.
5. Alarm Control Panels are available with many features & can control other devices such as smoke detectors, fire detectors & burglar alarms.

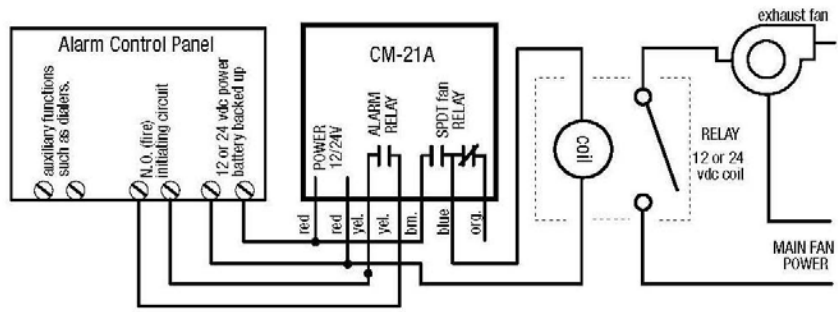

### Power Up

## ! WARNING

Each time the unit is turned on it performs a self-test, which activates visual alarms. If the self-test fails, or all the alarms do not activate, do not use. Failure to do so may adversely affect product performance and **result in sickness or death**.

The CM-21A steps through a self test cycle for the first 2 1/2 minutes that it is powered. The unit will execute the test cycle any time power is dropped and reapplied (ex. power failure). During the self-test cycle:

1. The Fan relay will be activated for the entire cycle (therefore the fan should run, if the system is wired to exhaust carbon monoxide).
2. The Alarm relay will turn on for the first 10 seconds of the self-test cycle, and be open for the remainder of the cycle.

The indicator light (LED) can display three different colors: green, amber and red. During the self-test cycle, the light on the CM-21A will turn alternately between red and green. At the end of the 2 1/2 minute cycle, the unit will take its first carbon monoxide sample and the light will turn solid green.

### Operation

Once the unit has finished the self-test cycle and the light is on continuously, the color of the light then indicates the relay condition. If the light is **green** neither of the relays should be activated. If the light is **amber** the Fan relay should be activated. If the light is **red** the Fan relay & Alarm relay should be activated. If the unit detects an improper voltage or inoperable component it will default into Error mode. In Error mode, the light is off and both the Fan & Alarm relay will be actuated. The CM-21A samples the air and updates its outputs every 2 1/2 minutes. **Nothing you do will cause a change until the next 2 1/2 minute cycle.**

## ! WARNING

Do not cover or obstruct visual alarm LED. Doing so may adversely affect product performance and **result in sickness or death**.

The CM-21A default **Fan Relay** setting is activation at 35 ppm of CO within 5 minutes. The default **Alarm Relay** setting is Normally Open with activation at 100 ppm of CO within 3 hours and/or 200 ppm within 10 minutes.

### Selecting Fan Relay Level

There are two jumpers: J1 and J2 that control the fan relay level. Use this table to set the fan relay control.

Fan relay setting (ppm)	J1	J2
25	Off	On
35	On	On
50	On	Off
100	Off	Off

### Selecting Alarm Relay Operation

The Alarm Relay output can be selected to be NO - Normally Open (Default) or NC - Normally Closed by the insertion or removal of J3 Jumper. For Normally Open Alarm Relay ensure that the J3 Jumper is On the J3 location on the circuit board. For Normally Closed Alarm Relay ensure that the J3 jumper is removed from the circuit board.

### Onboard Diagnostics

The CM-21A monitors all critical functions of the unit through software diagnostics that continuously test and verify unit operations. If a problem is found, the unit will switch to a fail-safe mode/error mode. In this error mode, the Fan and Alarm relays will be activated and the light will Flash Amber. This is a safety precaution. To clear this mode, simply turn off power to the unit for a few

seconds, or push the TEST switch (inside the unit). This will cause the unit to restart the 2 1/2 minute self-test cycle. If the error mode repeats frequently, check for continuous power and proper voltage. If power is not the problem, and a unit has repeating error conditions, it may need to be returned to Macurco for service, per instructions below.

### **Brown Outs**

Occasionally, a lower than normal line voltage can cause the CM-21A to become erratic and inoperable. To clear this condition, reset power to the unit, by turning it off for a few seconds, then back on.

### **Sensor Poisons**

The gas-sensing tip in the detector is designed with extreme sensitivity to the environment. As a result, the sensing function of the tip may be deteriorated if it is exposed to a direct spray from aerosols such as paints, silicone vapors, etc., or to a high density of corrosive gases (such as hydrogen sulfide, sulfur dioxide) for an extended period of time.

### **MAINTENANCE**

The CM-21A does not require regular maintenance. The unit uses a self-purging semi-conductor sensor that has a 7-10 year life expectancy. All maintenance and repair of products manufactured by 3M are to be performed at the appropriate 3M manufacturing facility. 3M does not sanction any third-party repair facilities.

## **WARNING**

Do not disassemble unit or attempt to repair or modify any component of this instrument. This instrument contains no user serviceable parts, and substitution of components may impair intrinsic safety, which may adversely affect product performance and result in sickness or death.

### **CAUTION**

- Avoid the use of harsh cleaning materials, abrasives and other organic solvents. Such materials may permanently scratch the surfaces and damage the display window, labels, or instrument housing.

### **Cleaning**

Cleaning of the external surfaces is best carried out using a damp cloth with a mild detergent or soap.

### **Calibration Verification Test**

## **WARNING**

Using a certified gas with a concentration other than the one listed for this instrument and sensor when conducting a calibration or calibration verification test (bump test) will produce inaccurate readings. This means that higher levels of the gas being monitored may be present and could result in overexposure and **cause sickness or death**. For proper use, see supervisor or *User Instructions*, or call 3M in U.S.A., 1-800-243-4630. In Canada, call Technical Service at 1-800-267-4414.

### **General**

Normally this will be the only test required for the CM-21A and is the recommended way to test the unit or units after installation. All CM-21A units are factory calibrated and 100 % tested for proper operation. The unit also has the ability to test itself automatically and does so every 2 1/2 minute cycle. If the unit detects an improper voltage or inoperable component it will default into Error mode. In Error mode, the light is off and both the Fan & Alarm relay will be actuated. Check that the CM-21A OPERATING LED type light is illuminated, continuously. If not, do not proceed with the tests. If the unit is in error mode contact your local representative or Macurco service technician for information on resolving the problem.

### **Testing**

1. Remove the single screw in the middle of the front cover of the CM-21A.
2. Remove the front cover.
3. Locate the switch labeled TEST on the right side of the printed circuit board.
4. Observe the color of the LED light on the front of the CM-21A.
5. If the light is green proceed to step 7.
6. If the light is any color except green, refer to the OPERATION section above.
7. Push the Test switch once.
8. The CM-21A will step through a 2 1/2 minute test cycle:
  - a. The light will alternate between red and green
  - b. During the first 10 seconds of the Test cycle, the Alarm relay will be closed, so any devices connected to that relay will be tested
  - c. The Fan relay will be activated for the full 2 1/2 minutes of the test, so if the fan circuits are wired in the normal manner, the fan should run
9. At the end of the test cycle, the light will turn green and be on steady (Normal Operation) and the Fan & Alarm relay will be in standby mode
10. When testing is completed reassemble the unit or units

## Carbon Monoxide Gas Test (Optional)



The following steps must be performed when conducting a calibration or calibration verification test (bump test) to ensure proper performance of the monitor. Failure to do so may adversely affect product performance and **result in sickness or death**.

- When performing a calibration or calibration verification test (bump test) only use certified calibration gas at the required concentration level. Do not calibrate with expired calibration gas.
- If the instrument cannot be calibrated, do not use until the reason can be determined and corrected.
- Do not cover or obstruct display, audible alarm opening or visual alarm cover.
- Ensure sensor inlet is unobstructed and is free of debris.

### General

A Field Calibration Kit (CME-FCK) is needed to complete a CO gas test. The kit includes a cylinder of 50 ppm of carbon monoxide (CO) in air to test the Fan Relay and a cylinder of 200 ppm of CO in air to test the Alarm Relay. These are available through your local representative or from Macurco.

### Notes

1. All units to be tested must be powered continuously for a minimum of **72 hours**
2. For optimum test results it is suggested that the unit be in clean air (green light on) and be in a low ambient air flow

### Gas Testing

#### Testing the Fan Relay

1. Remove the Philips screw on the front of the CM-21A. Remove the front cover.
2. Open the FCK. Connect the 50 ppm gas cylinder to the regulator.
3. Check the pressure gauge on the regulator. If you have 25psi or less you will need to replace the gas canister.
4. Place the white cap from the regulator over the CO sensor. Turn on the regulator to start the gas flow.
5. Wait 6 minutes with the gas applied continuously.
6. The light should turn amber within the 6 minute time frame, and the fan relay should activate, along with the connected fan circuits.
7. Remove the gas from the sensor after 6 minutes. Proceed to Test the Alarm relay or replace the top cover.
8. Note: If the Fan relay does not close within 6 minutes, there are four possibilities:
  - a. Gas cylinder is empty, check the pressure gauge. Replace the gas cylinder if 25psi or less.
  - b. Unit needs to be re-calibrated (go through recalibration and re-test).
  - c. Detector is in need of servicing (return unit to factory for servicing).
  - d. Detector has fan relay set to 100 ppm. Use a jumper on J2 to set the fan relay to 25 ppm and repeat the test. Remove the jumper once the test is complete.

#### Testing the Alarm Relay

1. Connect the 200 ppm cylinder of carbon monoxide to the regulator.
2. Check the pressure gauge. If there is 25psi or less the cylinder should be replaced.
3. Place the white cap from the regulator over the gray device labeled FIGARO TGS 203 (the CO sensor). Turn on the regulator to start the gas flow.
4. The Fan relay should activate after about 5 minutes and the LED should turn amber.
5. The Alarm relay should activate within 10 minutes of gas application. The LED should turn red and the alarm relay should activate.
6. Remove the gas from the sensor after 6 minutes. Proceed to Test the Alarm relay or replace the top cover.
7. See four possibilities in “Note” above if Alarm relay fails to activate.

### 3M FIXED GAS DETECTION PRODUCTS LIMITED WARRANTY

3M warrants the CM-21A gas detector will be free from defective materials and workmanship for a period of two (2) years from date of manufacture (indicated on the inside cover of the CM-21A), provided it is maintained and used in accordance with 3M instructions and/or recommendations. If any component becomes defective during the warranty period, it will be replaced or repaired free of charge, if the unit is returned in accordance with the instructions below. This warranty does not apply to units that have been altered or had repair attempted, or that have been subjected to abuse, accidental or otherwise. The above warranty is in lieu of all other express warranties, obligations or liabilities. **THE IMPLIED WARRANTIES OF MERCHANTABILITY AND FITNESS FOR PARTICULAR PURPOSE ARE LIMITED TO A PERIOD OF TWO (2) YEARS FROM THE PURCHASE DATE.** 3M shall not be liable for any incidental or consequential damages for breach of this or any other warranty, express or implied, arising out of or related to the use of said gas detector. Manufacturer or its agent's liability shall be limited to replacement or repair as set forth above. Buyer's sole and exclusive remedies are return of the goods and repayment of the price, or repair and replacement of non-conforming goods or parts.



#### FOR MORE INFORMATION

In United States, contact:

Website: [www.3M.com/OccSafety](http://www.3M.com/OccSafety)

Technical Assistance: 1-800-237-9049

©3M 2008

#### For other 3M products:

1-800-3M-HELPS or 1-651-737-6501

#### 3M Occupational Health and Environmental Safety Division

3M Center, Building 0235-02-W-70

St. Paul, MN 55144-1000

98-0060-0149-3 (rev.1)